

About General Panel Corp

General Panel Corp (GPC) is a division of Perma R Products, Inc., which has been in the EPS products manufacturing business since 1978. In addition to the Panel Plants in Union, MS, and Johnson City, TN, Perma R has an Insulating Concrete Foam business and General EPS Form Products Plant in Johnson City, TN, and the Corporate Offices and EPS Plant in Grenada, MS.

General Panel Corp was formed in October 2001, when Perma R Products acquired the assets of Apache Panel in Union, MS. It was determined that a new organization to meet the needs of our panel customers was appropriate, so General Panel Corp was formed.

The Johnson City, TN, General Panel Plant has always oriented its operation toward timber frame enclosure, and, as a result has specialized in 4' x 8' to 4' x 16' panels for a wholesale market. We have also increased our market share of contractor and owner/builder, fully structural and timber frame enclosure and log and commercial roof. We have the capability of laminating a large array of skins.

The Union, MS Plant has specialized in wholesale and contractor fully structural panel construction projects with very little timber frame enclosure and as a result has developed substantial competence in jumbo (8' x 24') panel fabrication. Our capabilities for close tolerance, finely engineered fabrication is unexcelled in the industry.

GPC Panel Specifications

General Panels are foam core sandwich panels which utilize APA rated oriented strand board (OSB) and other skins laminated under

pressure (over one ton/sq. ft. in a platen press) to MEPS (expanded polystyrene modified for flame spread and smoke developed to meet Building Code Standards). Standard foam core thicknesses are consistent with lumber thicknesses to allow better options on site for plates, splines, headers and bucks. Panel sizes run from 4' x 8' to 8' x 24' and standard core thicknesses are 3-5/8", 5-5/8", 7-3/8" and 9-3/8". Custom foam core sizes are also available.

When installed in accordance with this manual and the appropriate construction details, General panels are much stronger than stick frame structures of equal thickness. As a result, it is easy to engineer General Panels as a substitute for stick frame on most house plans.

The instructions and construction details that follow are intended to help you build correctly, but they are not intended to supercede specific directions and details on your panel plans. They do not apply to panels manufactured by others. Many details vary with geographical location, and the best technique in one area may be the worst choice in another area. This holds particularly true for all moisture-related issues. Temperature and ambient moisture, inside and out, are significantly different in different climates, and are a major issue in building "supertight" homes of any kind, including SIP homes.

General Panel Corp Panels as Fully Structural Panels

When GPC panels are used as directed as fully structural panels, no support (other than a ridge beam or other span support) other than the panels is necessary. Floor panels are splined (or double or triple splined) to achieve the floorspan necessary with spans of as much as 16' o.c.

Wall panels straddle and are fastened to a base plate, are splined together by a dimensional lumber spline, and a top plate is inserted into a recess at the top of the panel to form wall sections in accordance with panel drawings specific to each plan. Roof panels span from ridge beam to eave (or purlin) in spans of up to 16' o.c. Alternatively, panels can span up to 16' o.c. across rafters.

Typically both skins are OSB in fully structural panels. Significant limitations to structural value or longevity apply to all skins other than OSB. Finished skin alternatives are susceptible to environmental hazard and degradation which can substantially shorten the useful life of the structure, but often they are used as a short term measure to allow timely completion of a building with an intention of re-siding within four or five years.

Additional skins may be laminated to OSB/OSB panels to achieve the strength and finish desired (example: OSB/OSB/GYP), but they are seldom used due to problems with rough electrical and handling.

Storage and Handling

Panels are shipped, usually by semi-flatbed, for ease of off-loading with forklifts or cranes. If the panels will be stored as stacked for more than a few days, they should be blocked as level as possible with "stickers" (stack blocks) not more than 16" o.c. to keep from "cupping." It is also a good idea to tarp the stacks with a translucent material to avoid greenhouse sweating. Access and off-loading are the contractor/home builder's responsibility.

Fire Blocking

Although the modified EPS used in SIPs is not

a good fuel for fires, the trapped air and residual Pentane do add to the flammability of the other construction materials in your house including the OSB, so Building Code requires the use of a Code Approved 15 minute barrier (typically 1/2" drywall or 5/8" T&G). Additionally, all panel terminations at the perimeter of a panel floor, at wall corners, and at the roof perimeter must be edge stopped with inset dimensional lumber 2" (nominal) or greater.

Sealant Between Panels

The need to seal between panels is determined by the installer, but sealant is strongly recommended, especially in areas where humidity is high or where there is a likelihood of air or humidity flow at the seam which could result in moisture damage to the panel, spline or other material. Panels can be ordered with sealant channels (keyways) manufactured into the panel to expedite sealing or panels can be gapped slightly to allow the sealant to be applied to the seam after installation.

Ventilation

Mechanical ventilation is usually required to remove excess moisture in panel homes because leakage is greatly reduced, allowing considerably more build up of moisture in panel homes than desirable. Additionally, if properly constructed, a panel home will be too "tight" for effective ventilation without mechanical help. The most often used system in the areas served by GPC is a heat pump coupled with a dehumidifier. In many areas in the country, an air to air heat exchange unit is recommended.

Panel Plans

It is highly advised that you obtain panel plans for any structure where panels will support roof or point loads or where panels will act as

headers. Final approval of the details (dimensions, opening sizes and locations, panel thicknesses, etc.) rests with the buyer/builder, so it is imperative that the plans be carefully reviewed. It is very easy to misinterpret plans and revisions in the drafting process, so only the panel plans are the responsibility of the fabricator, but panels cut to the plans which are wrong are the responsibility of the buyer/builder.

Panel plans contain specific construction details and dimensions that are critical to the structure and which must be complied with. It is important to note that it may be necessary to vary from these standard instructions in different climates and given different Building Code issues. Different Code Authorities require different approaches to meet regional needs.

Assembly

Structural Panels are engineered for strength and longevity. It is critical that panels are properly secured to one another and to appropriate structural members.

Follow all guidelines for fastener spacing, adhesive and sealant on the panel plans. The standard, if no panel plans exist, is 6" o.c. for all panel attachments to wood.

Factory Fabricated Panels

Most structural panel projects are fabricated at the factory. This means that the cutting and routing required by the panel plan have been done in the factory and that the panels are labeled to coincide with the panel plans. Usually, the panels will be stacked to optimize shipping space, so it is critical to review the shipment as soon as possible to ascertain that all panels have arrived. If any panels are missing, identify them by panel number to your

sales representative and the panel will be promptly manufactured and fabricated to get to you. Although a quality assurance check is made prior to loading, it is possible that panels could be miscut or misinterpreted. Any improperly cut panels will be re-manufactured and fabricated and re-shipped ahead of all other work.

Site Fabrication

For a variety of reasons (fabrication backlog at the factory, cost, personal involvement in the building process, considerable fitting to pre-existing situations, etc.), you may wish to fabricate on site. Fabrication consists of layout, cutting the skins and foam, and routing the edges to match the requirements of the panel plans.

The tools of the trade are standard circular saws, beam saws, chain saw attachments (Prazi or Linear Link), electric chain saws, foam scoops, hot knives, routers and grinders, and foam guns. Essentially, panels are cut to the shapes and dimensions on the panel plans, routed (or scooped) at the edges per panel plans and then labeled (panel number)

Waste

One major advantage of using panel plans is that waste can be minimized by matching ripped sections and kneewall/header sections to reduce waste. Although EPS is recyclable, it is difficult to separate the EPS from the skin in a recyclable usable way, so the best alternative is to minimize waste in the planning and execution of the panel drawings. Any site waste should be disposed of properly. Waste created during the fabrication of panels at our plant is available to you, if you request it. Otherwise, it is disposed of subsequent to manufacture.

Design

Although panel construction is often more expensive than conventional stick built construction, this can be minimized or overcome by proper design. Panels have considerable labor embedded in them, and to the extent that this labor can be utilized by not further fabricating the panel, cost is reduced. Additionally, panels represent higher material costs and lower labor costs, so anything which minimizes material will make panels relatively less expensive. In addition, the primary cost item in structural panels is OSB, which comes in standard sizes, so designs which use standard sizes have less waste. This means that, to produce a 9' panel, 3" (12 sq. ft.) of OSB is removed and discarded from each side, making 9' panels cost more than 8' or 12' panels per sq. ft. Therefore any design which takes advantage of these precepts will minimize panel cost.

Normally in 4' x 8' style SIP construction, doors and windows use a kneewall/ header configuration to maximize header strength, so it makes sense to use full panels abutting the outside edges of the openings and scrap pieces above doors and windows makes good economic sense. It also makes good sense to design around the roof first to utilize span advantages of panels and to try to minimize waste.

Panel Connections

Panels need to be joined to one another, to floors and roofs, and to supporting lumber. The connection details are critical to the integrity of the structure.

PANEL TO PANEL—ABUTTING

Although many splines systems have been tested and proposed, standard dimensional lumber splines are typically used for a number of reasons including cost, ease, fastener

requirements, adjustability, and racking and shear strength. The spline runs in the same configuration as a wall stud for wall, or a rafter for roofs. The edge of the panel is relieved of foam for 3/4" (half rout-single spline), 1-1/2" (full rout-double spline), or more and dimensional lumber is fitted to one panel and fastened and then the second panel slips over the spline (tongue and groove fashion) to create the attachment at the abutting edges.

The primary objections to the use of dimensional lumber splines are energy efficiency reduction and the use of additional old growth timber for splines. Recent testing has indicated that the reduction in energy savings due to 2X versus OSB splines or thermal splines is much less than was previously thought to be the case. It appears that the overall energy cost increase due to using 2X splines is on the order of 2% or less. Given the substantial increase in strength (racking and wind shear walls, deflection and span for floors and roofs), this seems a reasonable trade.

The standard panel spline for fabricated panels at our Union Panel Plant is 3" LSL. Two-by splines are also available.

With regard to old growth timber usage, SIPs still use considerably less lumber than conventional construction and engineered lumber alternatives are available to truly committed builders/homebuyers.

Typically dimension lumber splines are joined by six-penny nails or 1-1/2" coarse drywall screws. Adhesive is a good idea, but is only necessary in high wind areas or where specifically required by the engineering or panels plans. Expanding foam is also useful to stop gaps at panel seams,

but is only necessary in high humidity areas and in climates with extremely low winter humidity where the temperature is expected to remain below freezing for three or four days at a time and interior humidity will be maintained in excess of 50% relative humidity.

PANEL TO PANEL–CORNERS

Terminations of panels at wall ends must be filled with dimension lumber to meet fire restrictions in the Building Code, so the easiest method of joining panels at corners is a “butt corner.” The first corner (with embedded 2X) adjoins the second panel (also with embedded 2X) at 90 degrees to form a corner a long panel fastener passes through the first panel into the embedded 2X on the second panel. These fasteners are installed at 6" o.c. in the same manner (Details 4 and 5).

KNEEWALL HEADER

The kneewall and header attachment is critical to transfer the roof or floor load evenly through the panel. Please see Details 8 & 9 for the method of attaching the kneewall and header panels to adjacent panels.

BUCKS

Bucks are the dimensional lumber which line doors and windows and allow attachment of the doors and windows (Detail 7).

BEAM POCKET

Beam pockets spread the force of the point loads for structural beams and allow for even support from posts or splines. Essentially, beam pockets work the same as window and door bucks.

PANEL TERMINATION

Panel terminations should always be filled with 2 by material as a physical barrier to fire and infestation.

Timber Frame Home Panel Use

Structural Insulated Panels (SIPs) are the enclosure system of choice for timber frame structures for a number of excellent reasons:

- SIPs can be installed in significantly less time than any other enclosure, reducing the time the frame is exposed to the elements.
- SIPs can be pre-fabricated to further hasten installation on site for a much more rapid close-in.
- SIPs are the best possible humidity control to allow long term aging of the frame. This reduces twisting and checking.
- The reduced labor and quicker close-in translates to reduced final cost on the structure.
- Nothing insulates better than SIPs.

Typically, SIPs used for timberframe enclosures are splined using OSB (single or double). Nailbase panels are typically not splined, but tightly sealed using low-expanding foam and secured to the structure using panel fasteners (screws).

Use of Panels in Log Homes

Structural Insulated Panels (SIPs) have a number of uses in log home construction projects. Often, gable ends are much more cost effective and easier to do in SIPs. Occasionally, a bump out or bay can be done with SIPs more easily. Certainly, floors, roofs, and dormers are best done in SIPs.

SIPs are the only building project system which insulates in the same way as log systems, utilizing solid insulation with thermal mass, which makes them highly compatible with log building systems. Additionally, SIPs can be pre-fabricated to hasten installation on site for a much more rapid close-in than is possible using conventional stick frame construction.

Use of Panels in ICF Construction

Structural insulated Panels (SIPs) have a number of uses in Insulating Concrete Form (ICF) construction projects. Often, gable ends are much more cost effective and easier to do in SIPs. Occasionally, a bump out or bay can be done with SIPs more easily. Certainly, floors, roofs, and dormers are best done in SIPs.

SIPs are the only building product system which insulates in the same way as ICFs, utilizing solid insulation with thermal mass, which makes them highly compatible with ICF building systems. Additionally SIPs can be pre-fabricated to hasten installation on site for a much more rapid close-in than is possible using conventional stick frame construction.

Construction Details

FLOORS

Panels make excellent floors. Their advantages include excellent insulation, spans up to 10' o.c., which can reduce foundation and underpinning costs, and rapid installation. The combination of the panel thickness and the supporting beam thickness generally rules them out for use as interior floors, but they are often used in floors which are part of the insulation envelope.

CEILINGS

Sometimes the best use of panels in the insulation envelope is as ceiling panels. This is especially true when a "cut up" roof is specified and flat ceilings are desired. The easiest way to install ceiling panels is with trusses, with the panels hung from the bottom chord and the truss prior to finished ceiling installation. The standard procedure for this type of installation is to set the panels on the wall tops, utilizing jacks (similar to a drywall ceiling jack) until the trusses

are set, then fastening the panels to the truss underchord with panel fasteners, and then removing the jacks. When specifying trusses for this application, make certain that the truss bottom chord is designed for the additional 4#/sq. ft. additional load of the panel.

RIDGE DETAILS

The standard connection detail for panels at the ridge utilizes a laminated, beveled ridge double spline over a beveled ridge plate over a ridge beam. Alternatives include a butt connection over a beveled ridge plate over the ridge beam or an unsplined bottom butt connection with a filler panel (very limited application) over a beveled plate over a ridge beam.

ROOF

Panels are used most for cathedral ceilings, and are unsurpassed in this regard. Drop ceilings are also possible, but usually more expensive than other alternatives.

BASEMENTS (SUB GRADE)

Perma R does not make panels intended for use below grade.

WALLS

Panels are often used for walls. 3-5/8" panels work in most circumstances up to 10' in height for up to two stories. If three stories are planned, the first story walls must be 5-5/8" core or greater. In high wind areas or seismic zones thicker panels may be necessary. Window and door openings up to 6' are best handled with panel headers (and kneewalls under windows), unless very large point loads are involved. Standard wall connection, door and window connections, spline connection options and plate connections follow.

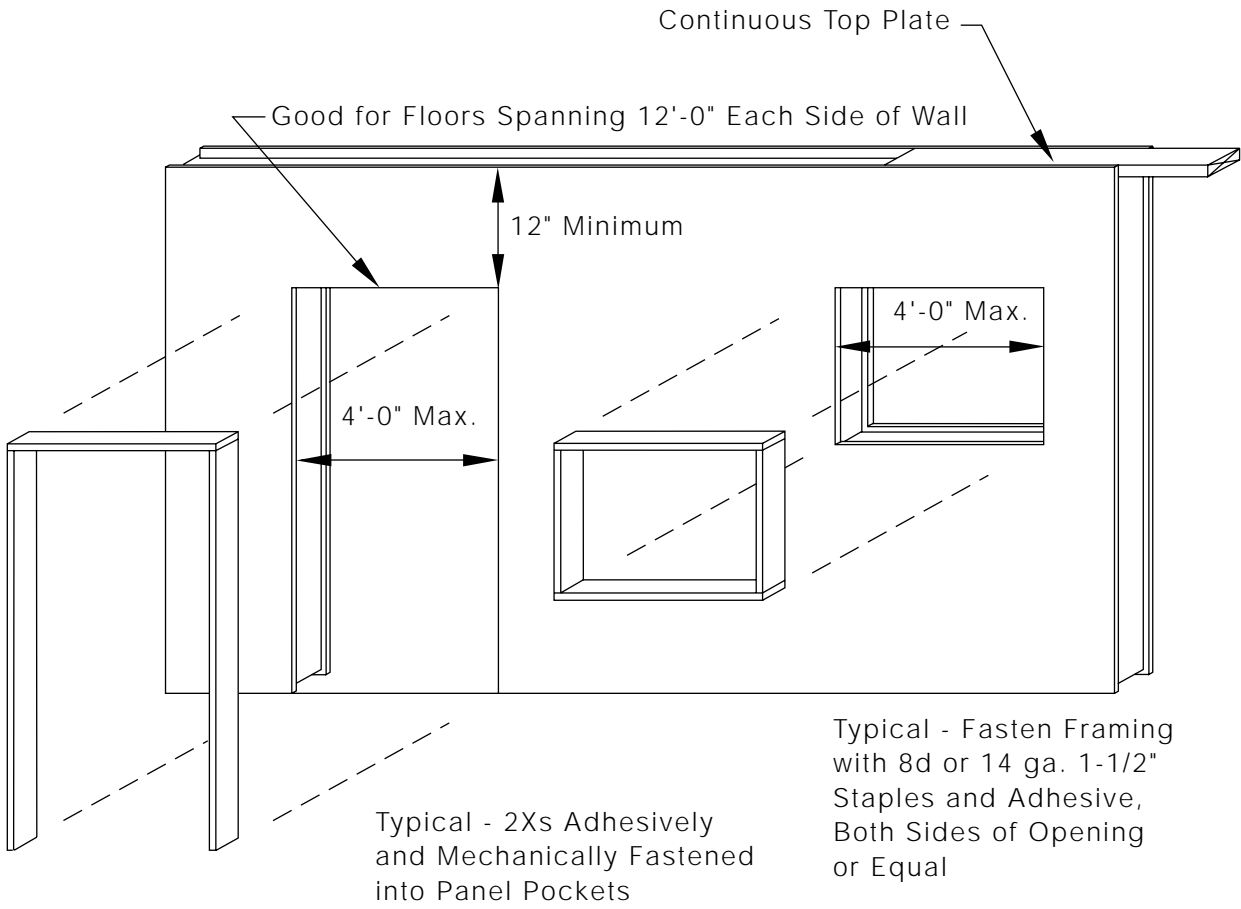

NOTE: *Sequence framing members as shown above.*
Splines may occur at any point in the wall.

ELEVATION VIEW



General Panel Corp	
TITLE: Wall Opening Details	NO.: 7

Opening Size	Exterior Wall	Interior Wall
4'	2 x 8	2 x 8
6'	2 x 8	2 x 10
8'	2 x 8	2 x 10
10'	2 x 10	2 x 12
12'	2 x 10	2 x 12
14'	1 x 12	-

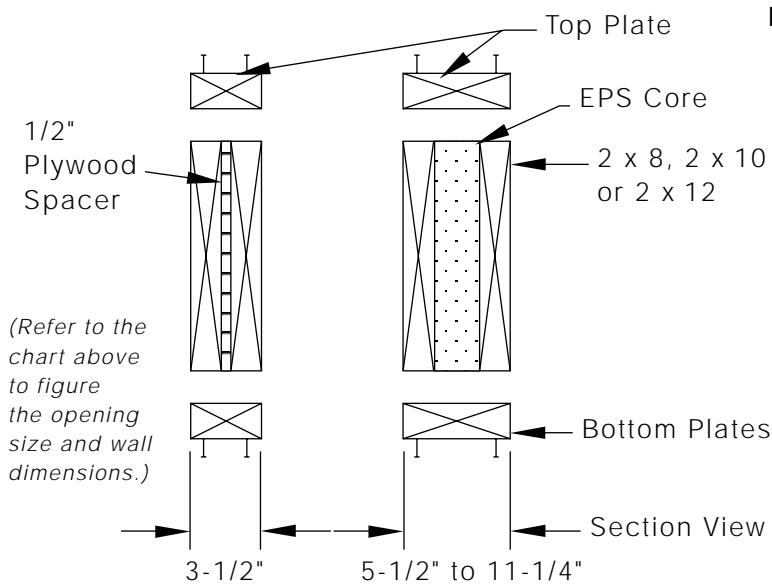
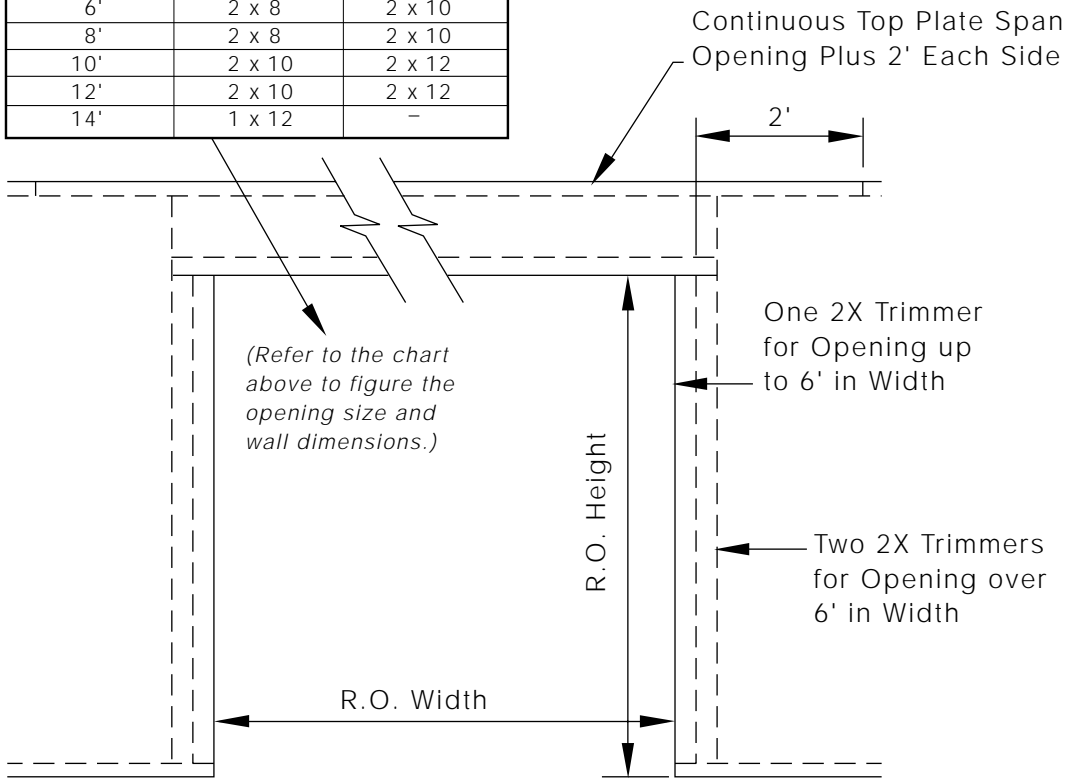

NOTE: Header designs are for typical continuous load design. Additional engineering may be required for unusual designs and extreme load conditions.

Top and bottom plates are required as shown. Fasten with 16d Nails at 8" o.c.

Pre-engineered beams of equivalent strengths may be used.

ELEVATION VIEW

GENERAL PANEL CORP

General Panel Corp

TITLE: Header Details

NO.: 8

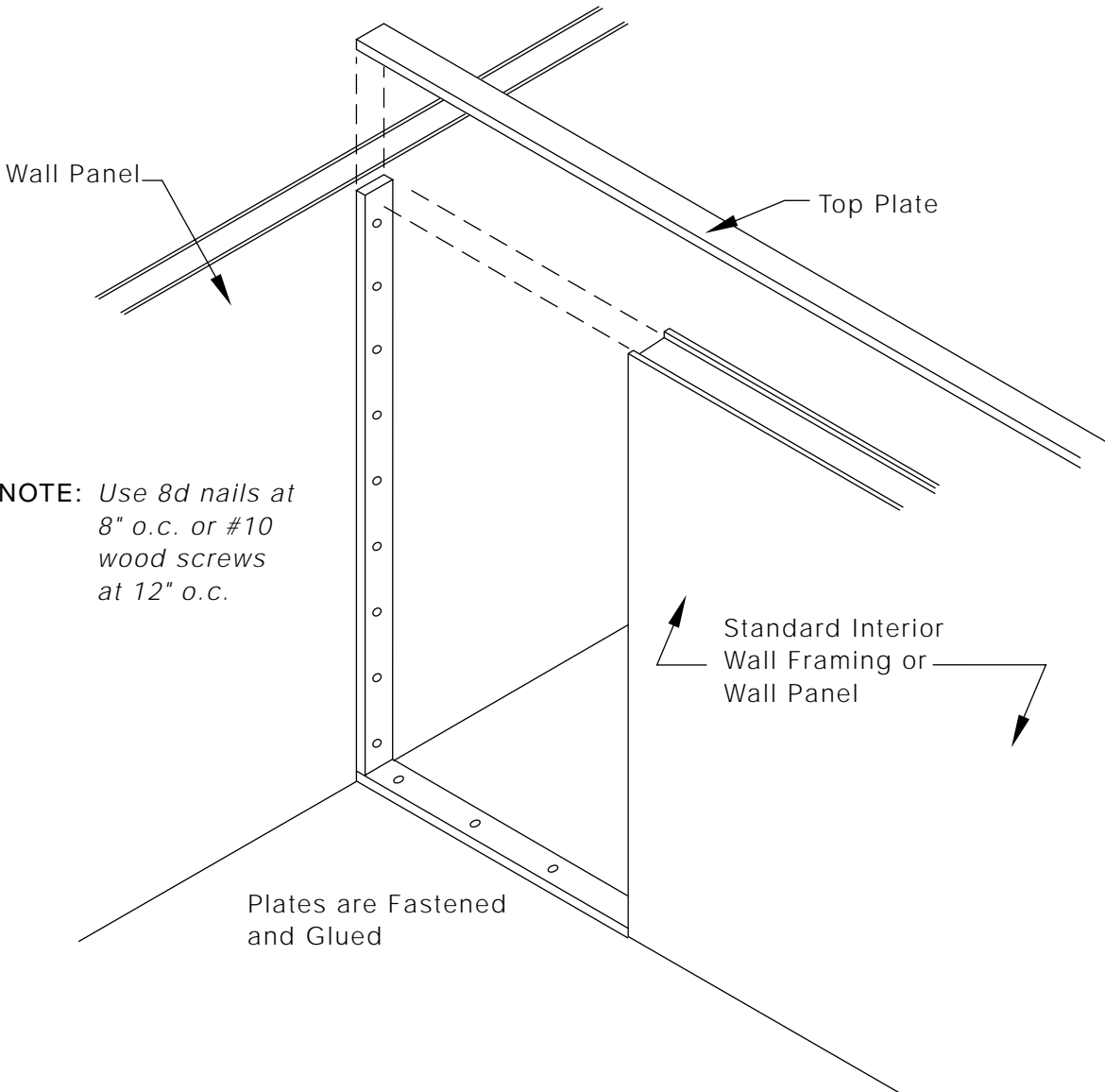

ELEVATION VIEW

GENERAL PANEL CORP

General Panel Corp	
TITLE: Interior Wall Connections	NO.: 10

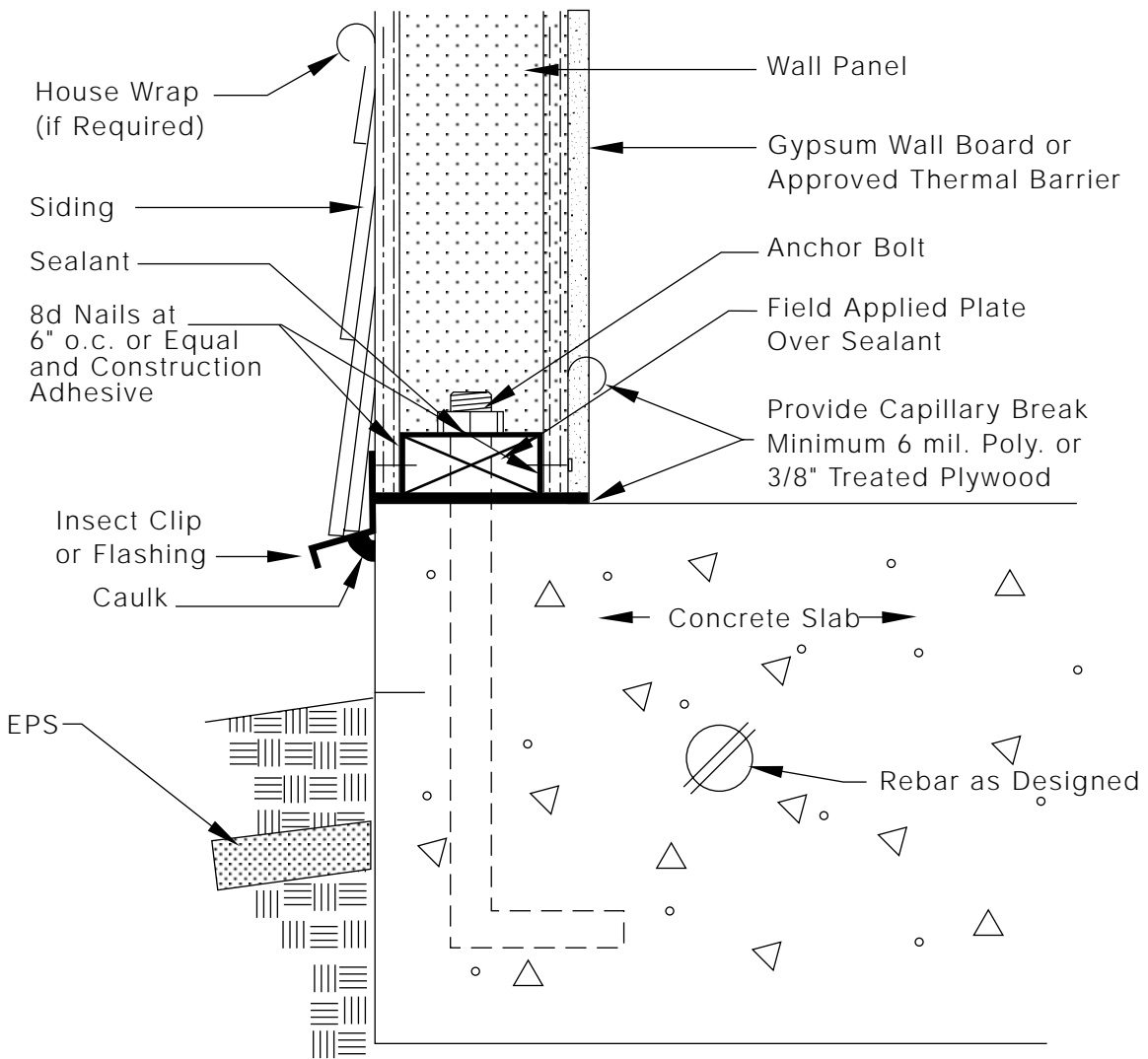

SECTION VIEW

GENERAL PANEL CORP

General Panel Corp	
TITLE: Wall / Slab Connection	NO.: 12

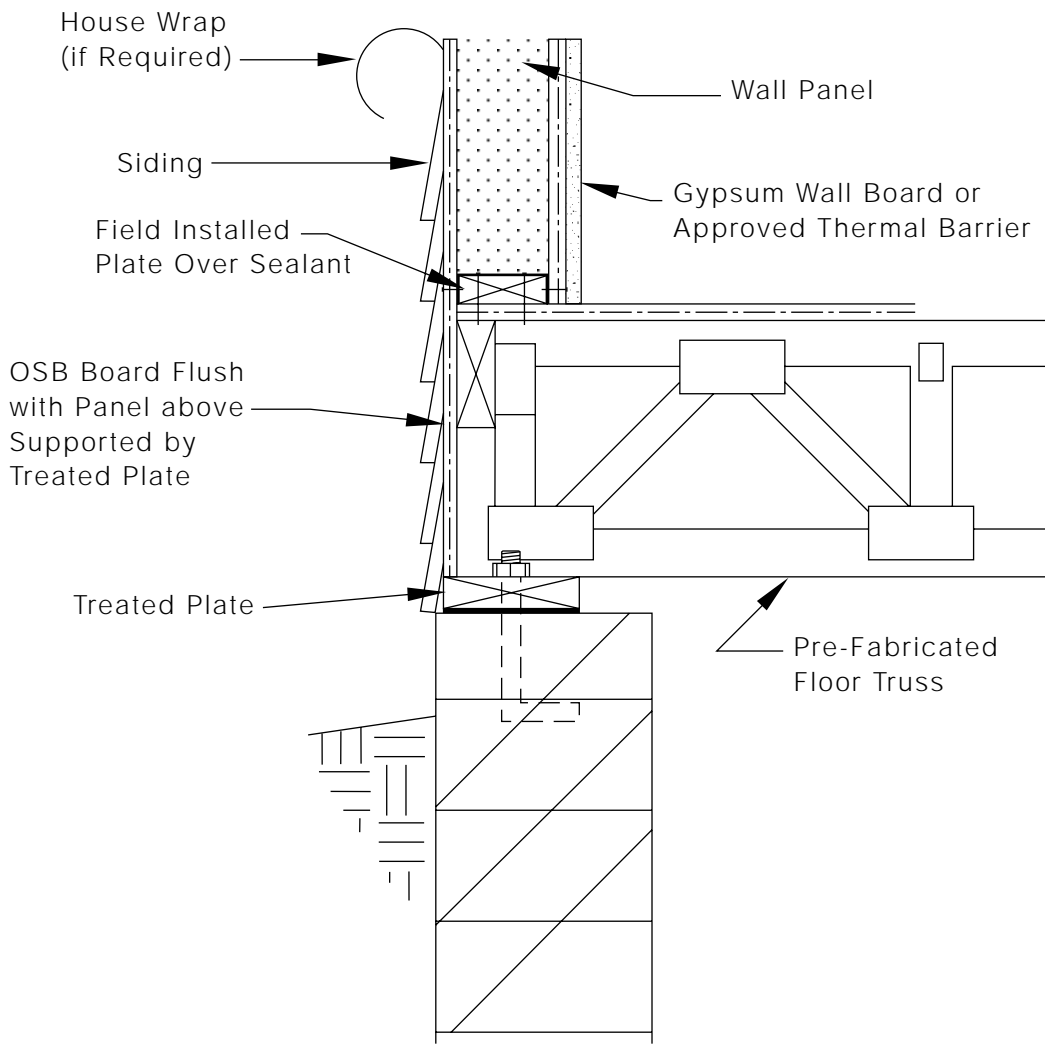

SECTION VIEW

GENERAL PANEL CORP

General Panel Corp

TITLE: Wall Over Floor / Pre-Fab Floor Truss at Foundation

NO.: 15

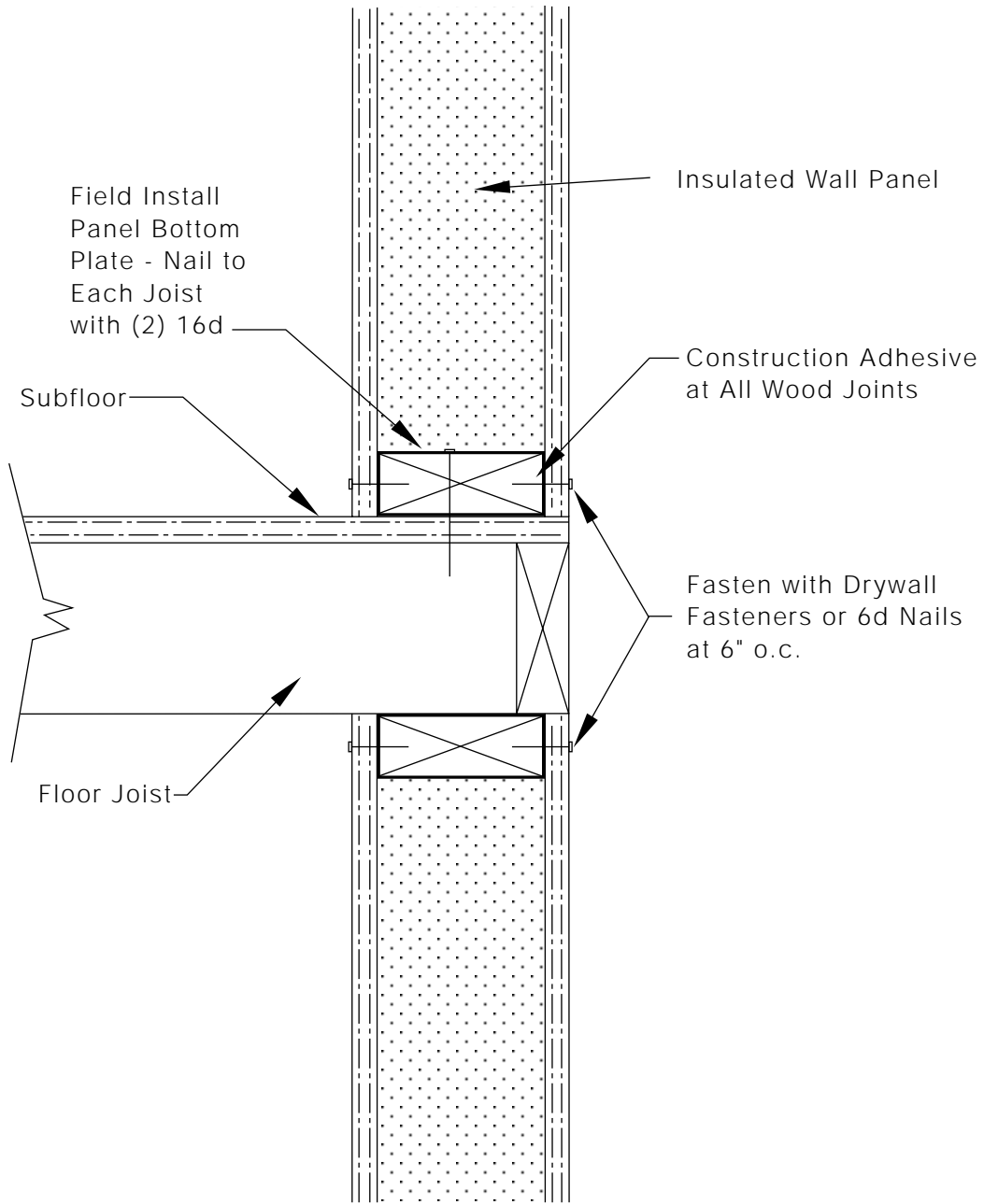

SECTION VIEW



General Panel Corp	
TITLE: Std. Interior Floor Detail / Rolled Trusses	NO.: 16

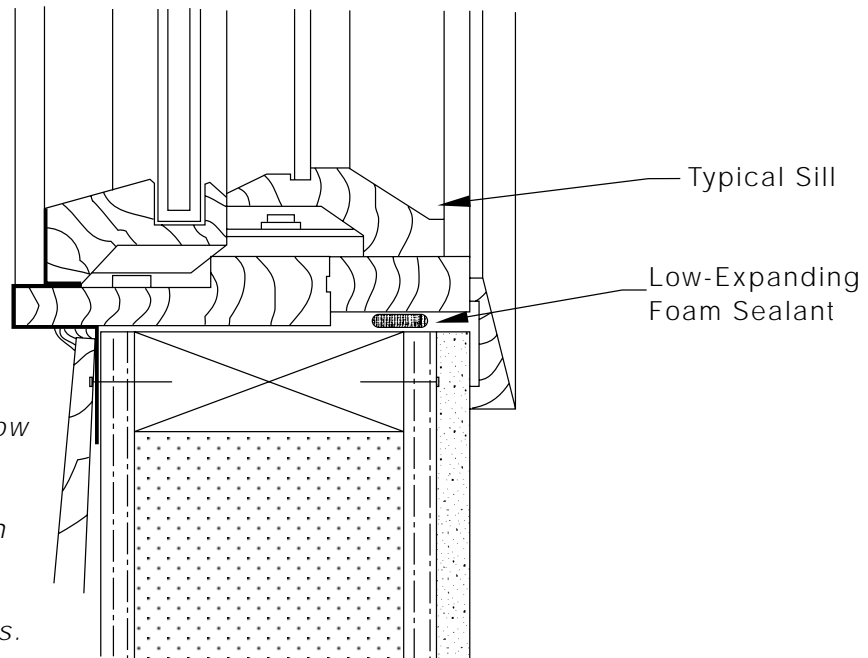
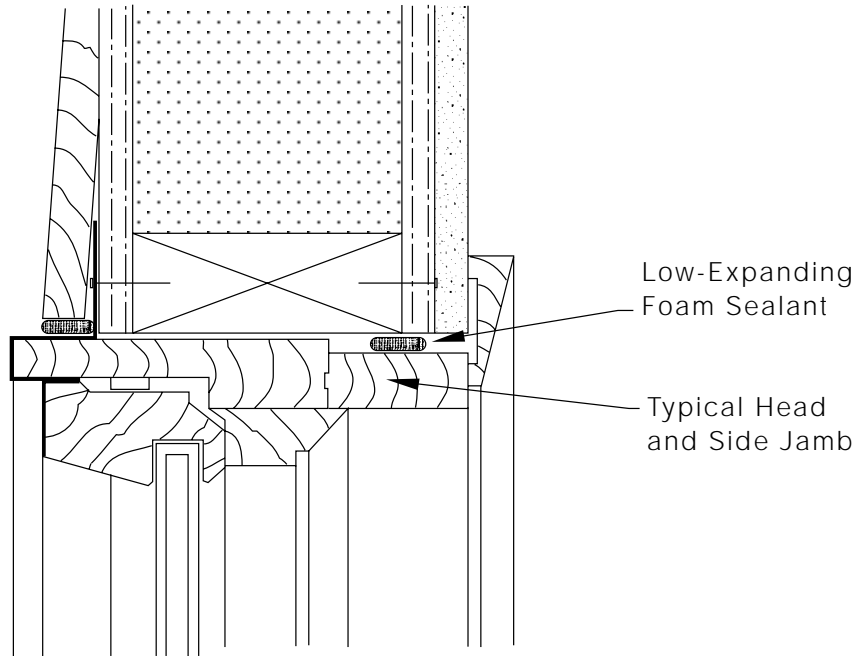

NOTE: Shown is a typical case-ment window detail. See window manufacturer's literature for details. Fasten in accordance with manufacturer's recommendations.

SECTION VIEW

GENERAL PANEL CORP

General Panel Corp

TITLE:
Window Details

NO.:
20

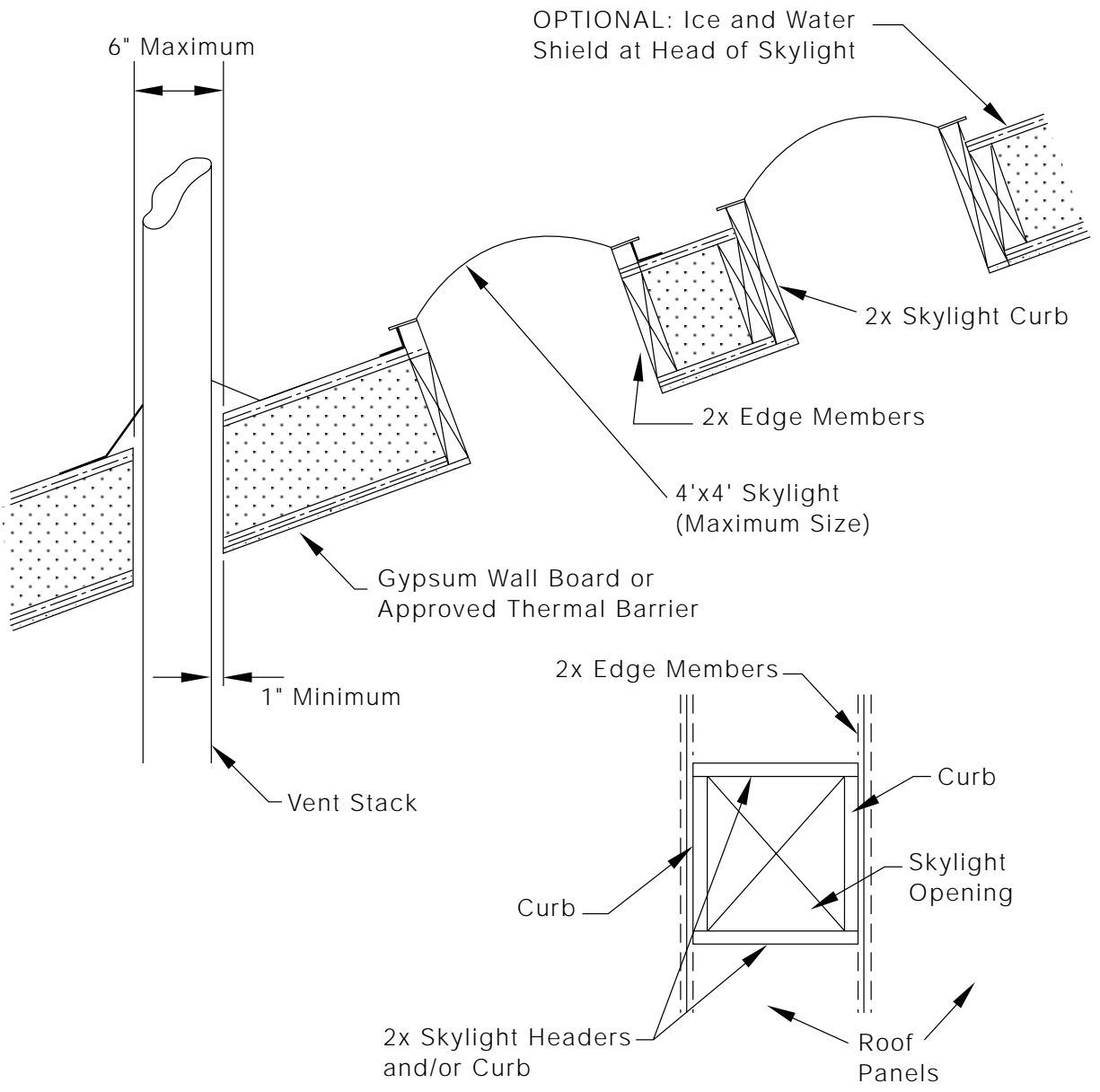

NOTE: Protect core from temperatures 160°F or above.
 Use zero clearance insulating material designed for high temperatures as required.

Roof penetrations exceeding 6" require blocking as shown for skylights in this detail.

SECTION VIEW

GENERAL PANEL CORP

General Panel Corp

TITLE:
 Skylight Details

NO.:
 23

NOTE: Attach Simpson clips with 8d nails on each panel side

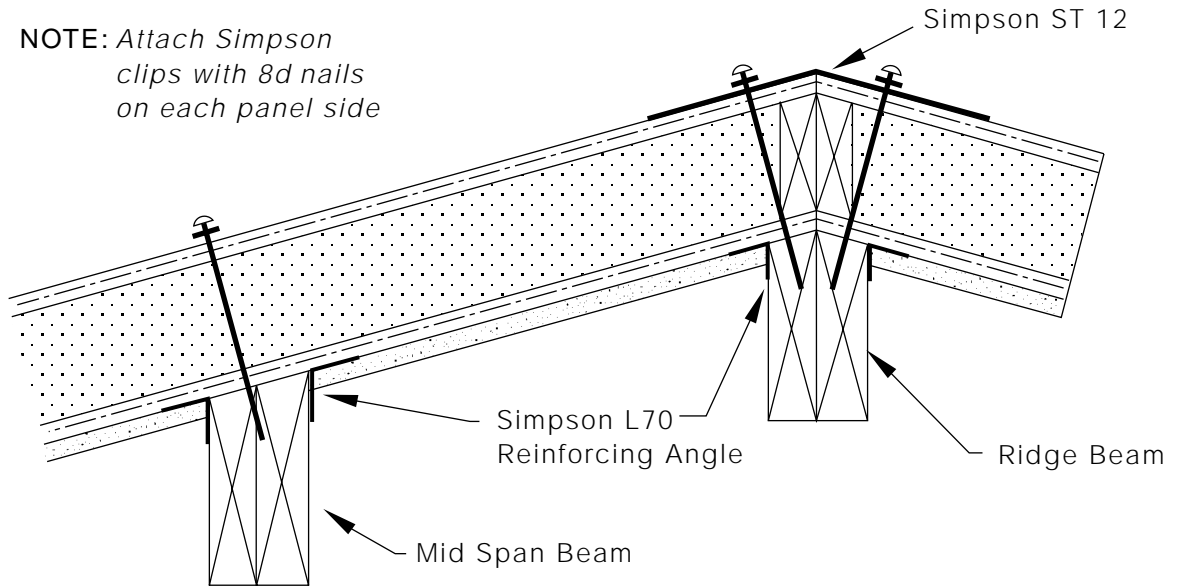

NOTE: Install all reinforcing metal at panel edges and/or 4' o.c.

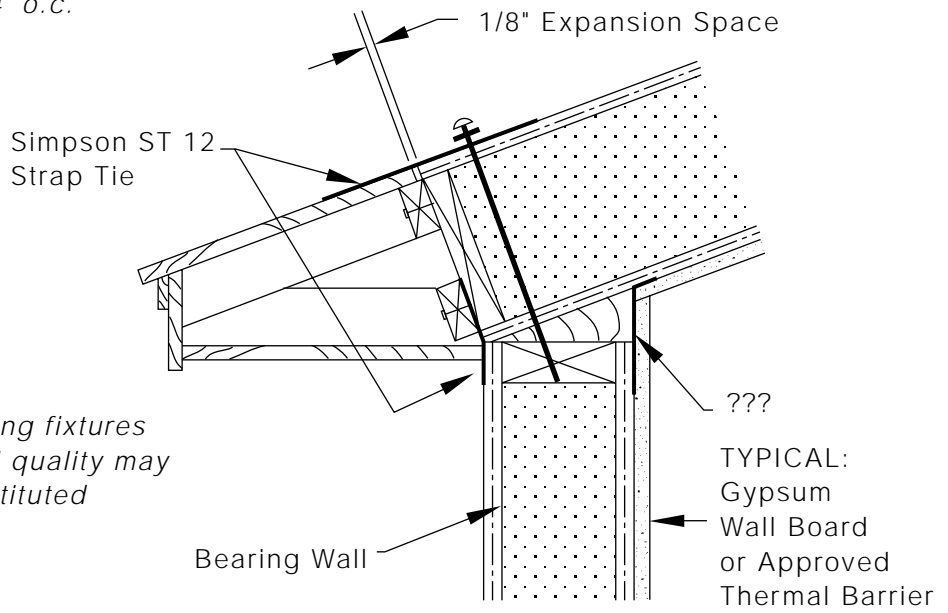

NOTE: Anchoring fixtures of equal quality may be substituted

SECTION VIEW

GENERAL PANEL CORP

General Panel Corp

TITLE: Ridge / Purlin Connections-Built Out Eave Soffit

NO.: 33

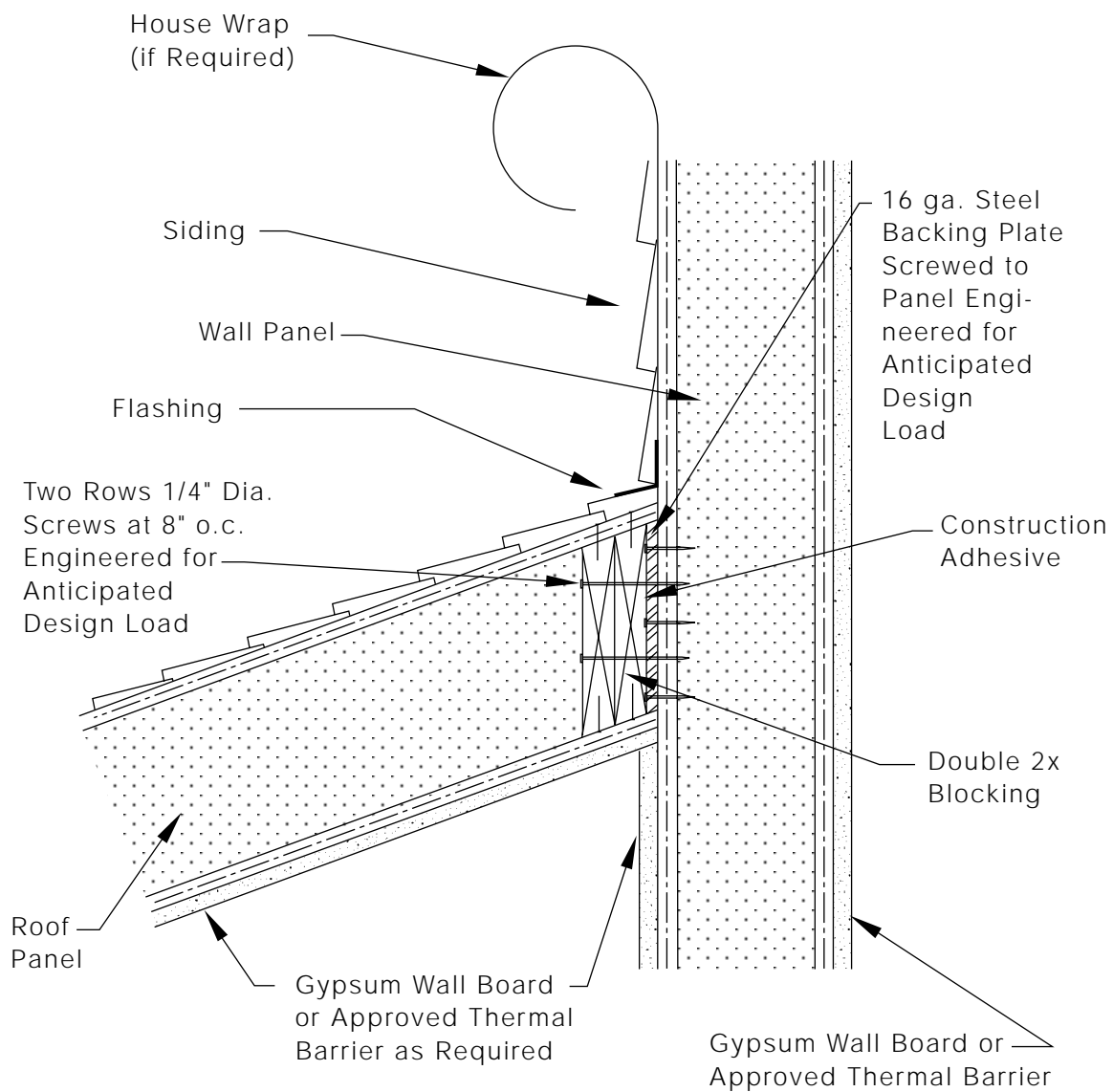

NOTE: Fasten 2X side members for roof panels to 2X blocking with framing angles (Simpson L 70).

SECTION VIEW

GENERAL PANEL CORP

General Panel Corp

TITLE:
Shed Roof Detail

NO.:
35

NOTE: Extend ice and water shield from fascia to 2' beyond wall line (if desired for cold region design).

SQUARE CUT

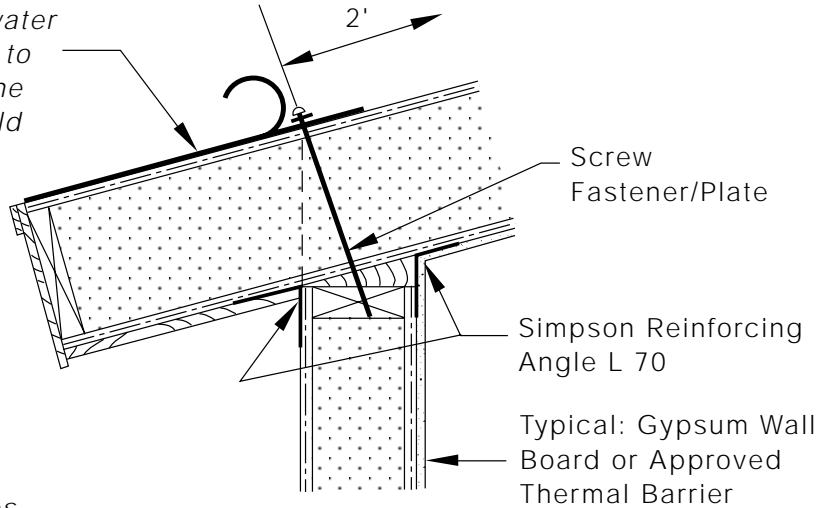

NOTE: Anchoring fixtures of equal quality may be substituted.

PLUMB CUT

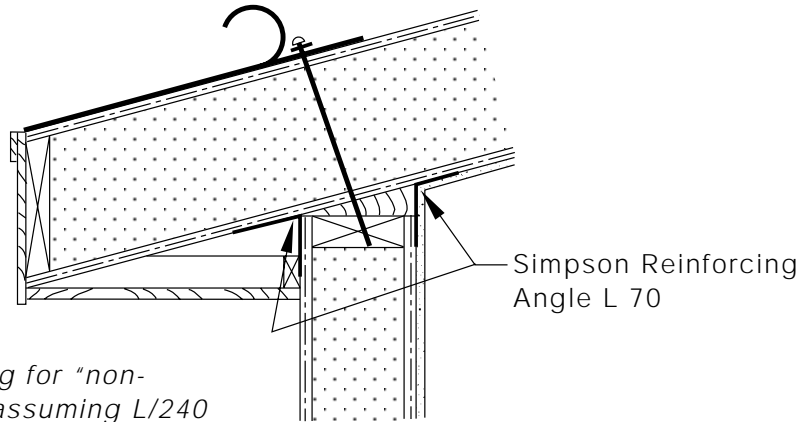

NOTE: Maximum 24" overhang for "non-frame" eave designs assuming L/240 design load, or as engineered for specific application.

NARROW FACIA

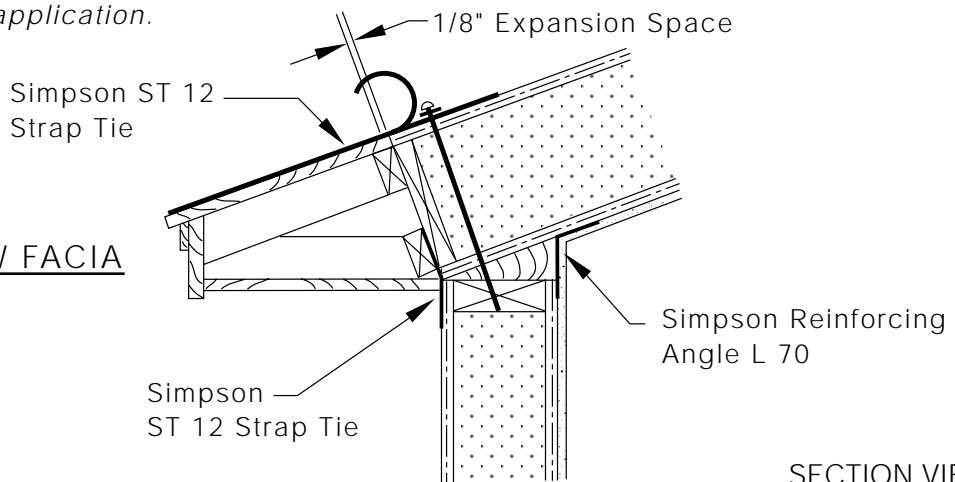

SECTION VIEW

GENERAL PANEL CORP

General Panel Corp

TITLE: Eave Details

NO.: 37